

Monaco & Cardrona Gas Fire



OWNER'S MANUAL & INSTALLATION GUIDE

These gas appliances have been tested in accordance with AS4553 (AG 103) NZS 5262 and have been certified by the Australian Gas Association for installation and operation as described in these Installation and Operating Instructions. Your unit must be serviced annually by an authorised service person.

WARNING: Improper installation, adjustment, alteration, service or maintenance can cause injury or property damage. For assistance or additional information consult an authorised technician, or your Masport Gas Fire Dealer.

FOR YOUR SAFETY: Do not store or use petrol or other flammable vapours and liquids in the vicinity of this appliance. Installation and service must be performed by authorised personnel. Please keep these instructions for further reference.

WHAT DO YOU DO IF YOU SMELL GAS

- Do not try to light any appliance
- Do not touch any electrical switch; do not use any phone in your building
- Immediately close the shut-off valve behind the heater or at the gas meter.
- Call the technician.

THE INSTRUCTIONS IN THIS MANUAL APPLY TO MASPORT MONACO SERIES 2 (S2) AND CARDRONA GAS FIRES.

THE MODELS COVERED ARE:-

NATURAL GAS (NG)	LIQUID PROPANE GAS	UNIVERSAL LPG (ULPG)
MONACO S2 ACC	MONACO S2 ACC	MONACO S2 ACC
MONACO S2 ECS	MONACO S2 ECS	MONACO S2 ECS
CARDRONA STD	CARDRONA STD	CARDRONA STD
CARDRONA ACC	CARDRONA ACC	CARDRONA ACC

IDENTIFICATION:- MONACO models have a single curved glass front.
 CARDRONA models have a three-piece glass front.
 STD = Standard ACC = Accessory ECS = Electronic Control System

CONTENTS:-	
OPERATING INSTRUCTIONS.....	1
Lighting the fire	1, 2, 3
Receiver switch positions	3
Turning off the fire.....	4
Cleaning instructions.....	4
INSTALLING INSTRUCTIONS.....	5
Heater dimensions.....	5, 6
Minimum installation clearances	5, 6
Positioning the heater.....	7
INSTALLING PROCEDURE.....	7
Gas	7
Thermostats.....	7
Gas pressure adjustment.....	8
Fan	8
Flue	9
Log and Ember placement.....	9
Seismic restraint.....	10
Test firing	10
MAINTENANCE INSTRUCTIONS.....	11
Access points.....	11
Glass removal and assembly	11, 12
Removing the burner.....	13
Routine maintenance	13
Wiring diagrams.....	14, 15
Data plates.....	15
Trouble shooting	16, 17
Annual Service Record.....	Back Cover

SPECIAL NOTE FOR APPLIANCES USING PROPANE AND ULPG GASES

IF YOUR APPLIANCE HAS NOT BEEN USED FOR AN EXTENDED PERIOD, YOU MAY
 FIND IT ADVISABLE TO PURGE THE PIPELINE TO MINIMISE DELAY
 DURING THE INITIAL LIGHTING-UP PROCEDURE.

**THIS BOOK CONTAINS IMPORTANT INFORMATION. IT MUST BE LEFT WITH THE
 PURCHASER TO BE KEPT IN A SAFE PLACE FOR FUTURE REFERENCE.**

WARNING.

Installation of all gas appliances **MUST** be carried out only by an Authorised Installer.

The heater must be installed according to these instructions and in compliance with all relevant building, gas-fitting, electrical and other Statutory Regulations (e.g. AS 5601 (AG-601), NZS 5261). Any shortcomings in the appliance and flue installation will be the responsibility of the installer, and Masport Ltd will not be accountable for any such failings or their consequences.

The guard is fitted to this appliance (Australia only) to reduce the risk of fire or injury from burns and no part of it should be permanently removed. For the protection of young children or the infirm, a secondary guard is required.

These appliances must not be installed in mobile homes.

NOTE: NOT INTENDED FOR FIREPLACE INSERT.

YOUR HEATER MUST BE SERVICED YEARLY BY AN AUTHORISED TECHNICIAN.

BEFORE INSTALLATION COMMENCES, check the data plate on the rear of the heater cabinet to verify that it is the correct type to suit your gas and also that the gas consumption rate is correct for your application.

ECS MODELS. The aerial wire is intended to protrude through the slot in the rear of the pedestal. **DO NOT PULL** this wire as this will dislodge the aerial circuit board.

IF THE APPLIANCE REQUIRES CONVERSION TO SUIT YOUR GAS, THIS MUST BE CARRIED OUT ONLY BY AN AUTHORISED TECHNICIAN WHO HAS THE APPROPRIATE GAS PRESSURE MEASURING EQUIPMENT.

OPERATING INSTRUCTIONS

DO NOT PLACE ARTICLES ON OR AGAINST THIS APPLIANCE.

DO NOT USE OR STORE FLAMMABLE MATERIALS NEAR THIS APPLIANCE.

DO NOT SPRAY AEROSOLS IN THE VICINITY OF THIS APPLIANCE WHILE IT IS IN OPERATION.

LIGHTING AND RUNNING THE FIRE:-

- Open the gas supply valve behind the appliance, if fitted.

CAUTION: If the fire has been alight, wait two to three minutes before re-lighting it.

NOTE - There may be a strong smell of paint curing the first time the fire is lit, but this will disappear.

STD CONTROL PANEL

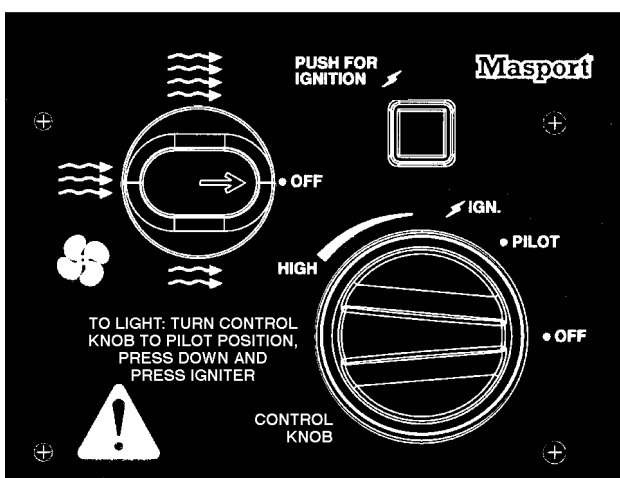

ACC CONTROL PANEL

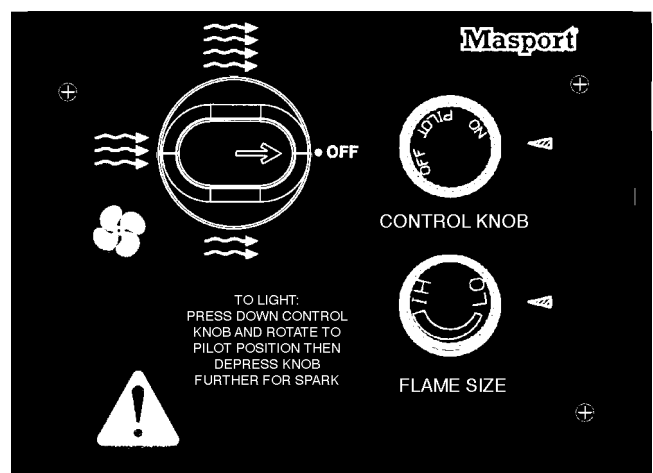

LIGHTING STD MODELS:-

- Press down on the control knob at the top of the heater and turn it anticlockwise to the 'PILOT' position. Holding the control knob down firmly, press the igniter button. The battery igniter will generate a continuous spark across the terminals at the pilot. If there is no spark, check the

battery (one AA alkaline cell) in the ignition module mounted on the back of the heater. (See page 5 or 6). If there is air in the pipeline, the pilot will not ignite immediately. The pilot is in front of the rear log, to the right of centre.

- As soon as the pilot lights, release the igniter button but keep holding the control knob down for 15 to 30 seconds after ignition. Release the pressure on the control knob – the pilot should remain alight when the knob rises. If not, repeat the above steps.

TURNING ON THE MAIN BURNER (STD models):-

- Turn the control fully anticlockwise to the 'HIGH' position and the fire will light at full heat. There may be a strong smell the first time the logs are fired but this will soon disappear.
- After ten minutes, set the control to give the desired heat output.
- At this stage you may turn on the fan by rotating the fan switch in either direction. The switch gives three speeds and has an 'off' position. No harm will result if the fan is left 'OFF'.

LIGHTING ACC MODELS:-

These can be in three configurations. They may be used as supplied (type 1), or they may be fitted with either a battery operated wall-mounted thermostat which is wired directly to the heater (type 2), or a thermostat contained in a portable remote control (type 3). With the type 3 option, a receiver is mounted on the stove pedestal (on either side, at the rear, facing forward) to sense the signal from the remote control. The remote control is battery powered, and the receiver can be either a mains operated or a battery operated type. (Instructions for fitting these optional thermostats are supplied with them.)

LIGHTING THE PILOT (All ACC models):- Note: To avoid the risk of backburning, do not attempt to re-light the fire less than three minutes after it has been extinguished. The pilot is in front of the rear log, to the right of centre.

The procedure for lighting the pilot is the same for all three ACC versions —

- Turn the FLAME SIZE knob fully anti-clockwise to the HI position. Push down and turn the CONTROL KNOB anti-clockwise to the 'PILOT' position. Press and hold the CONTROL KNOB down firmly. The battery igniter will generate a continuous spark across the terminals at the pilot light. If there is air in the pipeline, it may be necessary to hold the control knob down for some time before the pilot ignites. If there is no spark when the control knob is held down in the PILOT position, check the battery in the ignition module. It is mounted under the cover of the small black plastic housing mounted on the back of the heater (see page 5 or 6). One AA alkaline cell is required.
- Keep holding the control knob down for 15 to 30 seconds after the pilot ignites. Release the pressure on the control knob – the pilot should remain alight when the knob rises.
- Turn the control knob fully anticlockwise to the 'ON' position. **The main burner will not light until at least thirty seconds after the pilot is lit.**

TURNING ON THE MAIN BURNER (ACC models):-

When **no thermostat** is fitted (type 1) —

- Push down and turn the control knob fully anticlockwise to the 'ON' position and the fire will light at full heat.

When the **wall mounted programmable thermostat** is fitted (type 2) —

- First ensure that good batteries (3 x AA alkaline) are fitted in the wall thermostat, that the slide switch behind the hinged bottom cover is set to 'HEAT', and that the temperature setting on the thermostat is above the prevailing room temperature. Full details of the wall-mounted thermostat and programming instructions are supplied with it.
- Turn the control on the heater fully anticlockwise to the 'ON' position and the fire will light at full heat. There may be a strong smell the first time the logs are fired but this will soon disappear.

When the **IRRC 300 portable remote thermostat** is fitted (type 3) —

- First check that good batteries are fitted in the remote control. To fit batteries (two AAA alkaline), slide the cover below the display in the direction of the arrow and pull it further in the same direction firmly until it disengages. Ensure that the receiver has a 230 volt AC supply or battery as appropriate.
- Move the switch on the receiver control box (at the rear of the pedestal) to 'REMOTE'.

RECEIVER SWITCH: The receiver switch has three positions, 'OFF', 'ON' and 'REMOTE'. 'OFF' prevents the main burner from being lit. This is a useful safety feature if children might play with the remote control.

'ON' bypasses the remote control entirely, allowing the heater to be lit even though the batteries in the receiver or remote control are dead. In this setting the thermostat is inactive and the heat may be controlled manually.

'REMOTE' brings the remote control into full operation, allowing its in-built thermostat to match heat output to the heating needs of the area the remote control is in, **provided that the remote control is left pointing toward the heater**. The remote control can be set to automatically run the heater within any desired time period. See the separate remote control operating instructions for full details.

- Check the display on the remote control. If it reads 'OFF', aim the remote control toward the receiver and press the centre button on the remote to switch it to 'ON'. When the display shows 'ON', the SET TEMP will be displayed below the ROOM TEMP. For the burner to light, the SET TEMP must be *higher* than the ROOM TEMP. Raise the SET TEMP, if necessary, by pressing the right hand button.
- Turn the PILOT control fully anticlockwise to the 'ON' position and the fire will light at full heat.
- After about ten minutes, set the FLAME SIZE control to give the desired heat output.

FAN OPERATION (All ACC models)

- At this stage you may turn on the fan by rotating the fan switch in either direction. The switch gives three speeds and 'OFF'. NOTE. The fan is also controlled by an internal switch which will not permit it to start until the fire is hot (about ten minutes from cold on high fire) and will keep it running for some time after the fire goes out. No harm will result if the fan is left 'OFF'.

PROGRAMMING THE REMOTE CONTROL

The control can be programmed to operate the heater at a desired later time. The controls for this are under the sliding cover below the display. Programming instructions are in the instruction sheet supplied with the remote control.

LIGHTING ECS II MODELS:-

NOTE: Full instructions covering the capabilities of this system are detailed in a separate leaflet. Only basic instructions for MANUAL operation are given here.

CAUTION. To avoid the risk of backburning, do not attempt to re-light the fire less than three minutes after it has been extinguished.

ECS II models have an RF control system which does not require the remote to be aimed directly at the heater. They have a handpiece which incorporates the thermostat. If there is no display on the handpiece panel, check the batteries (4 AAA alkaline). When switched OFF, the display will show the day of the week, the time, the room temperature and OFF. See the leaflet for setting the correct day and time.

NOTE. Before using the remote, you must 'teach' the control system to recognise only your particular handpiece.

- Set the remote to OFF by pressing the ON/OFF button if necessary. (OFF will be displayed).
- Turn OFF the mains supply to the heater.
- Turn ON the mains supply to the heater and immediately press and hold both the FAN and PROG buttons for ten seconds. The display will show 'LC', and then revert to the normal OFF display.

LIGHTING THE HEATER

- Check that the power to the heater is switched ON, and that the gas tap is turned ON.
- Press the ON/OFF button. The display will now show one of three modes — MANUAL, AUTO or PROG plus possibly flame and fan symbols. In PROGRAM mode, the OFF may not change to ON, but the word PROG will be displayed.
- Press the AUTO/MAN button repeatedly to step through the three modes until you reach MANUAL. In this mode the thermostat in the handpiece is disabled so that the flame size and fan speed may be controlled as desired. The flame symbol may or may not be showing.
- If the flame symbol is showing, the ignition sequence will commence. After a deliberate time delay (about 7 seconds), the ignition sparking will commence, and if gas is available, the fire will light.

- If the flame symbol is not showing, press the '+' button. When it shows, the ignition sequence will begin as described in the previous paragraph.
- The first time you attempt to light the fire there will probably be air in the pipeline, so flame may not appear before the spark shuts down after about 30 seconds. If this happens, press the ON/OFF button and the flame symbol on the display will disappear. Then press the ON/OFF button again to restore the flame symbol when a further ignition cycle will commence. (Don't forget the 7 second delay between the remote calling for ignition and spark commencement). Repeat this switching OFF and ON as necessary until the gas comes through and the fire lights.
- The heater will always light at the HIGH setting, but will fall back to a lower setting after about 15 seconds unless the top heat setting has been selected.
- Repeated pressing of the '+' button will progress the flame through its six flame heights. The flame symbol on the display will increase in size as the higher heat outputs are selected. Press the '-' button, repeatedly if required, to diminish the flame to its minimum size.
- **When the flame symbol appears on the display**, the fan speed can be selected. Repeated pressing of the FAN button will step the fan speed through its three speeds and OFF setting. (LOW > MED > HIGH > OFF > LOW etc.). Turn the fan OFF by pressing the FAN button while the fan is in its HIGH speed setting. Fan speed settings are displayed to the right of the fan symbol by up to three wavy lines and a number. The more lines, the faster the fan speed.

NOTE. Your fan may be fitted with an internal heat operated switch (Thermodisc) to prevent it blowing cold air. This means that even though the display shows that the fan is switched on, the fan will not start until the heater has warmed up. The fan will then start automatically (after about ten minutes).

- The flame height and fan speed can be controlled as desired at any time. No harm will result if you turn the fan off (by repeated pressing of the fan button until the fan symbol disappears from the display), and keep the flame alight.

OPERATING IN MANUAL MODE

- To turn the fire on and off, simply press the ON/OFF button, checking that the display shows MANUAL. The flame and fan selections will resume their previous settings, but remember that the fan will not start until the fire has warmed up for about ten minutes if a Thermodisc is fitted.
- Full instructions for AUTO operation and PROGRAM setting are in the separate leaflet. Please read them to utilise the full potential of your control system.

TURNING THE FIRE OFF:-

ALL MODELS EXCEPT ECS :-

- Push down and turn the control to the 'PILOT' position. Alternatively, models fitted with wall mounted or portable thermostats may be shut down at the thermostat. The pilot will remain alight.
- If the fan is running, it will stop after the firebox has cooled.
- To extinguish the pilot light, press the PILOT control knob part way down and turn it fully clockwise.

ECS MODELS:-

- To stop the fire immediately, press the ON/OFF button once.

CLEANING INSTRUCTIONS

The outside of the cabinet and glass should need no more than an occasional wipe with a damp cloth to remove any dust which may have settled.

All visible flame gas heaters can produce small amounts of soot, particularly if the combustion air entry slots under the heater are obstructed or the aeration air inlets are clogged with lint.

After a time, the inside of the glass may require cleaning. To do this, carefully remove the glass (See Glass Removal and Assembly, pages 11 and 12), and clean the inside surface with a non-abrasive cloth and a non-scratching type household cleaning liquid. Replace the parts as detailed on pages 11 and 12, keeping fingerprints off the inside glass surface.

No other user maintenance should be necessary. If you require any other service or adjustments, contact your Installer or Dealer.

INSTALLING INSTRUCTIONS

MONACO HEATER DIMENSIONS

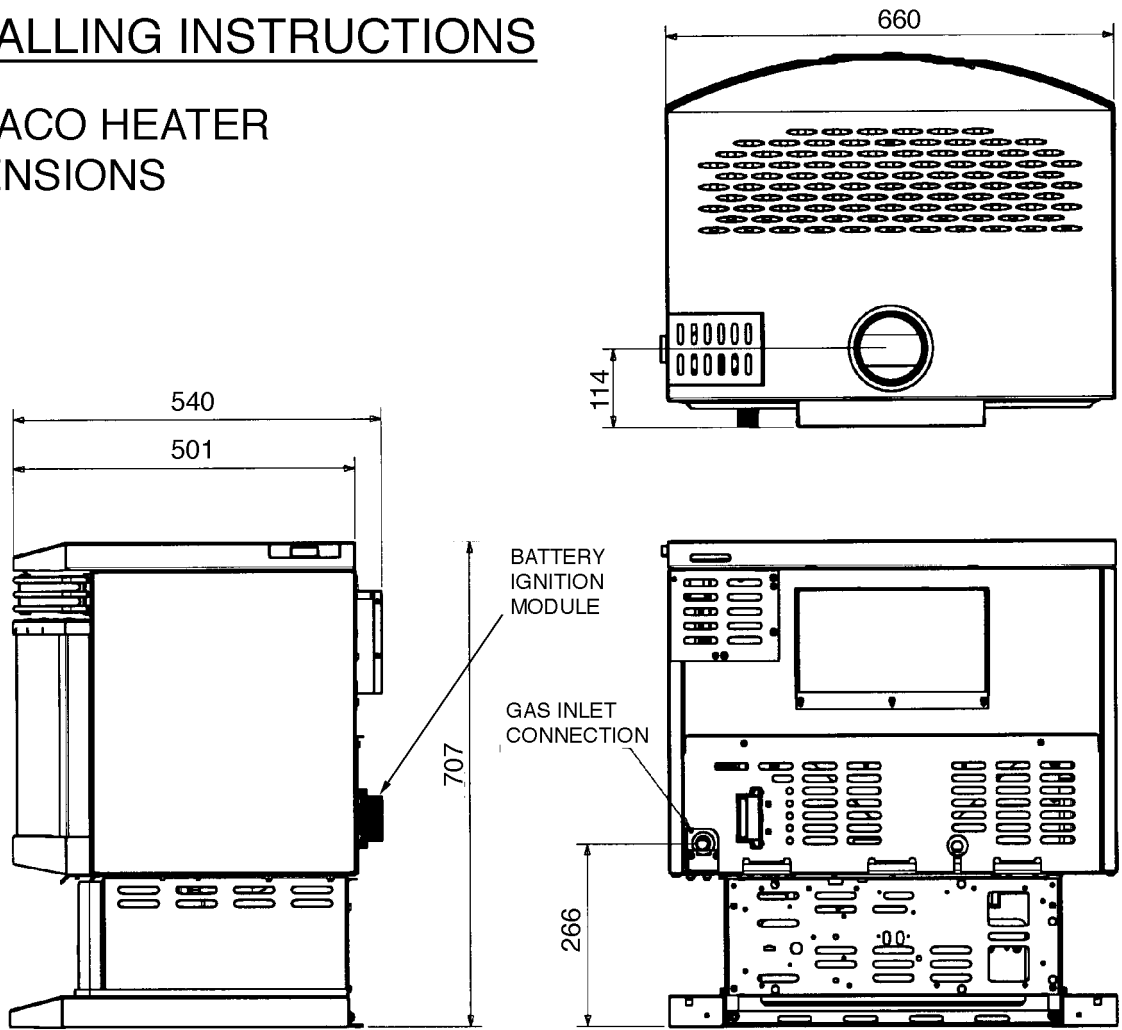

MINIMUM MONACO INSTALLATION CLEARANCES (To heat sensitive surfaces)

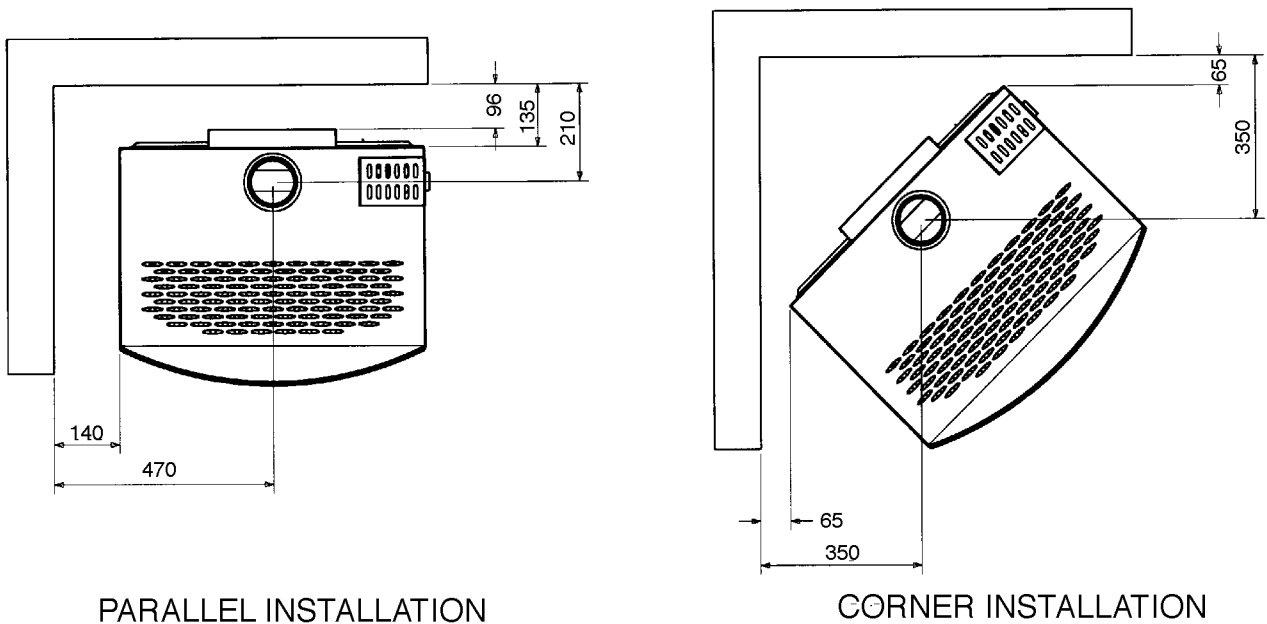

PARALLEL INSTALLATION

CORNER INSTALLATION

NOTE: The clearances shown are for fire hazard only. For durability of finishes or surfaces you should contact the relevant manufacturer for their specification. MASPORT accepts no responsibility for the deterioration of surfaces or finishes.

**NO FLOOR PROTECTOR (HEARTH) IS REQUIRED
ALCOVE INSTALLATION NOT PERMITTED**

CARDRONA HEATER DIMENSIONS

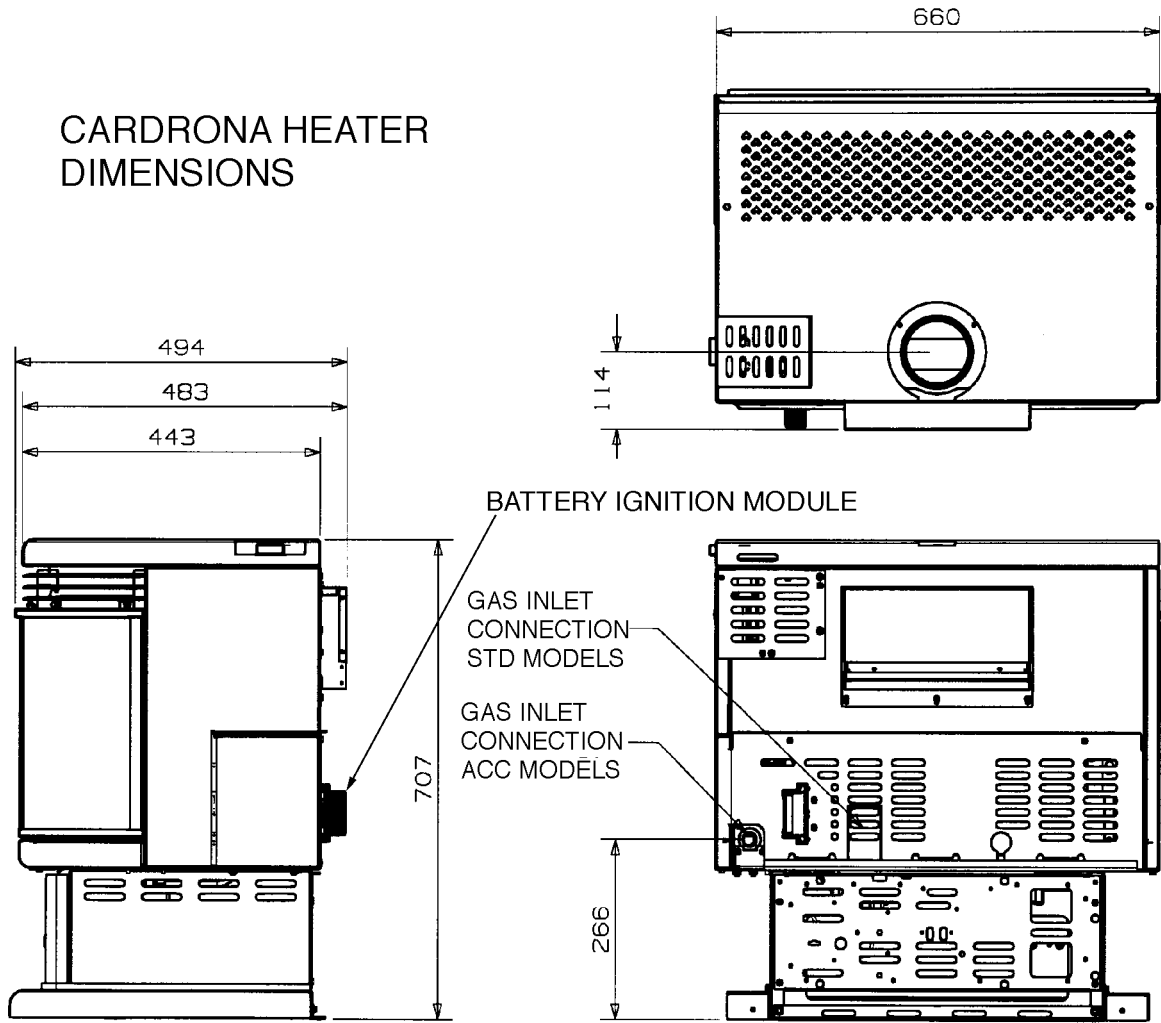

MINIMUM CARDRONA INSTALLATION CLEARANCES (To heat sensitive surfaces)

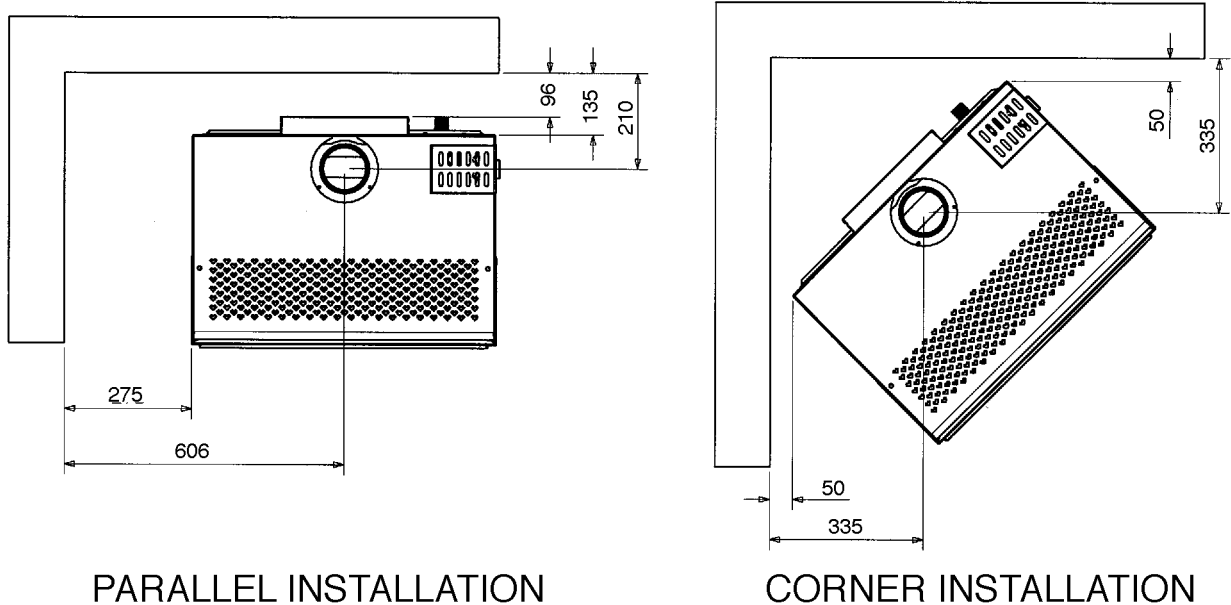

NOTE: The clearances shown are for fire hazard only. For durability of finishes or surfaces you should contact the relevant manufacturer for their specification. MASPORT accepts no responsibility for the deterioration of surfaces or finishes.

**NO FLOOR PROTECTOR (HEARTH) IS REQUIRED
ALCOVE INSTALLATION NOT PERMITTED**

POSITIONING THE HEATER

Select a dry site on any rigid flooring surface, keeping in mind the following:-

- A central position free of strong draughts will ensure even heat dispersal.
- Check that the flue and its shielding will be able to pass through the ceiling space and roof without interfering with any structural timberwork.
- The flue must terminate above the roof no less than 500mm clear of any part of the roof, and at least 1 metre horizontally from any neighbouring structure.
- The minimum specified clearance distances to heat sensitive materials **MUST** be maintained at all times, and sufficient room will be needed to facilitate servicing the heater.
- Avoid positions where curtains or furniture might accidentally come too close to the heater.
- Select a location where the gas supply can be installed readily. A power outlet will be required.

INSTALLING PROCEDURE

SHIMS (Cardrona Models). The glass panels are protected from shipping damage by paper shims fitted between the front and side glasses. Before lighting the heater, remove the shims after removing the dress guard, if fitted.

GAS. Access to the gas connection point is obtained by removing the cover panel on the rear of the cabinet. Remove the two screws and lift the panel up and out.

Connection is made to the STD models using a 3/8" BSP fitting. The ACC and ECS models use a 1/2" BSP fitting. In all cases a shut-off valve should be installed directly behind the heater to facilitate isolation of the heater for servicing.

It is essential to purge all gas lines before making the connection to the heater to eliminate any swarf.

THERMOSTATS

STD Models. A thermostat cannot be fitted.

ACC Models. Two accessory options are available:

- The hand-held IRRC Model 300 non-programmable remote thermostat.
- The wall-mounted programmable thermostat.

Instructions for installing both options are supplied with them.

ECS Models. An optional battery powered wall-mounted programmable thermostat is available.

GAS VALVES

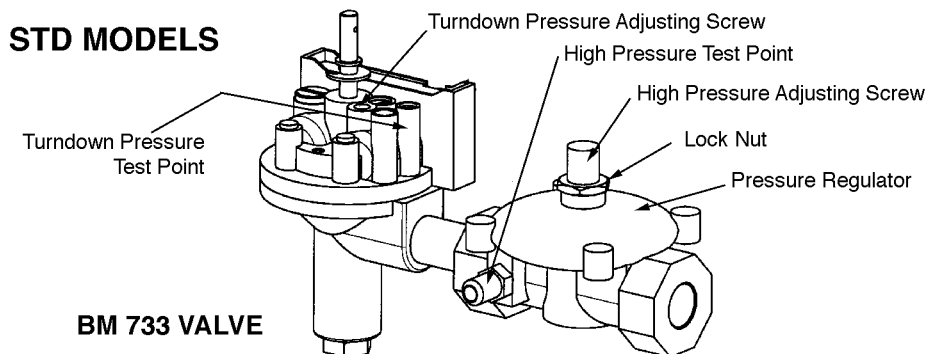
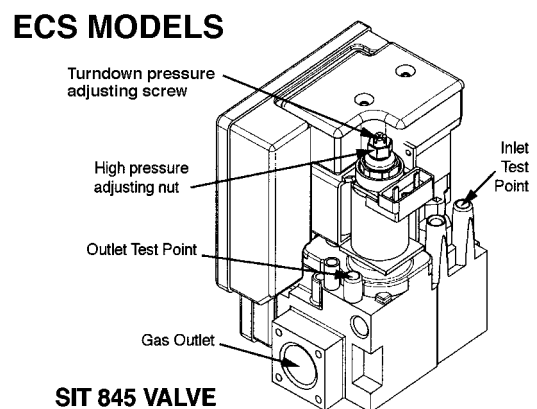
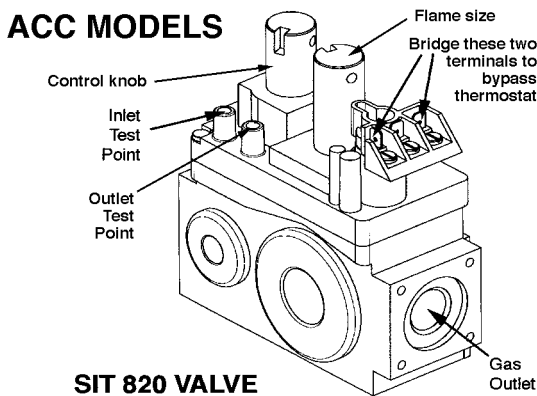

GAS PRESSURE ADJUSTMENT.

All pressure adjustments must be made while the heater is operating. Part or all of the right hand side panel of the cabinet may be removed to gain access to the gas valve. See ACCESS POINTS on page 11.

GAS PRESSURES kPa	ECS			ACC			STD		
	NG	ULP G	PROP	NG	ULPG	PROP	NG	ULPG	PROP
High Pressure	0.9	2.0	2.0	0.85	2.2	2.2	0.85	2.2	2.2
Turndown Pressure	0.35	0.5	0.5	0.43	1.36	1.36	0.23	0.7	0.7

STD MODELS. These have a pressure regulator separate from the control valve. Set the pressure to the figures in the Table. The pressure test point is on the side of the **regulator** and the adjusting screw is on the top. Slacken the lock-nut and rotate the screw by hand, screwing down to increase the pressure. After adjusting, tighten the lock nut and confirm the correct pressure. Use the pressure test point on the **valve** to check the turndown pressure. It is adjusted by turning the small screw on the valve.

ACC MODELS. These have a pressure regulator inside the control valve. There are two test points side by side on top of the control valve – the outlet pressure test point is the one closer to the flame size control. If adjustment is necessary, uncouple the control rod from the top of the flame size control knob on the valve, extract the screw down the centre of this knob and pull the knob off vertically. The high pressure is then set by rotating the knurled plastic wheel exposed by removing the knob. Once the pressure is correct (see Table), care must be taken not to turn the plastic wheel when the knob is re-fitted in its maximum anti-clockwise position. This position is set when the skirt of the knob contacts the adjacent metal up-stand. After re-fitting, rotate the knob clockwise and then fully anti-clockwise to verify that the pressure is correct before replacing the retaining screw and re-coupling the control rod. The turndown pressure is not independently adjustable. It should approximate the values shown in the Table.

ECS MODELS. These also have a pressure regulator in the control valve. The outlet pressure test point is on the top of the control valve and is the one furthest from the gas inlet connection. There are two pressure settings to adjust, high and turndown. Access to the adjusters is gained by first removing the heat shield above the valve and then removing the protective transparent cap at the top of the control valve modulating coil. This will expose the central screw (turndown pressure adjuster) and a 10mm hexagonal nut surrounding it (high pressure adjuster). Note that the modulating coil may be rotated through 90° if necessary to provide easier access for pressure adjustments. Before adjusting the high pressure, the fire must be alight and burning at the 'HIGH' setting. (Hold down the + end of the top rocker switch on the handpiece for 30 seconds to ensure this).

Set the high pressure first to the figure in the Table. Adjust, if necessary, by rotating the 10mm nut, screwing down to increase the pressure.

Before setting the turndown pressure, remove one of the blue wires connected to the top of the modulating coil. There is no need to alter the handpiece control setting. Adjust the turndown pressure to the figure in the Table by rotating the central Phillips head screw, taking care not to shift the position of the already adjusted 10mm hex. nut. Screw down to increase the pressure.

Replace the protective cap above the adjusters, re-fit the blue wire to the modulating coil, rotate the assembly above the coil to its original position and re-fit the heat shield above the valve.

FAN

STD MODELS. Plug the fan lead into a 230 volt power outlet and check that the fan operates correctly on all speeds.

ACC MODELS. These have a Thermodisc heat operated switch incorporated in the fan wiring circuit to prevent the fan from running until the firebox has reached working temperature. The fan can be started about ten minutes after the fire has been lit on 'HIGH'. When it starts, verify correct operation on all speed settings.

ECS MODELS. These have a Thermodisc also (see the previous paragraph). Once the firebox has heated up, check the fan operation by pressing the lower rocker switch on the remote control handpiece. Pressing the + end repeatedly will increase the speed through all four fan speed settings (three speeds and off), while pressing the – end will step it down through the speeds. Verify correct operation.

FLUE. USE ONLY AN APPROVED FLUE SYSTEM.

NOTE. For safe operation, the flue must be at least 900mm long (NG and PROP models) or 2.9m long (ULPG models).

1. Stand the heater in its proposed position, taking care to observe the minimum clearances shown on page 5 or 6. A floor protector (hearth) is not needed.
2. Drop a plumb-bob from the ceiling to hang centrally in the flue socket of the heater and mark the position on the ceiling. Drive a small nail through at this point and inspect the ceiling and roof to ensure that the flue and its trim will be at least 25mm clear of any combustible material. The flue termination requirements stated in 3 below will also need to be met.
3. Cut appropriate holes through the ceiling and roof material and install the flue in accordance with the instructions accompanying it, taking care to provide any safety clearances specified in the instructions (usually 25mm between the flue shield and any nearby combustible material). The installation must meet the requirements of AS 5601 (AG 601) or NZS 5261 as appropriate. The top of the flue must be above the roof, at least 500mm clear of any part of the roof and at least 1 metre horizontally from any neighbouring structure. All flue sections must be securely coupled to each other.
4. Flash the flue at the point of exit through the roof, to prevent water entry, and fit the flue cowl.

It is the responsibility of the installer to ensure that the flue system is operating correctly. See 'TEST FIRING' below.

LOG AND EMBER PLACEMENT

Access to the firebox can be gained by removing the firebox glass. See GLASS REMOVAL in the MAINTENANCE INSTRUCTIONS (pages 11 and 12).

The heaters are shipped with the logs wired together, and they should be already in their correct places, but the embers must be placed after installation. The wires serve no function after shipping, but they may be left in position when using the fire without any adverse effects. The log identification and positioning are shown below in case the logs have been dislodged during transit or if they have been removed for access to the burner. Any broken or damaged logs must be replaced, and correct positioning of the logs is vital for the burner to operate properly. The logs sit on the threaded posts at the top of the burner, and a large flat washer fits over each of the six front posts before fitting the log.

Spread embers between and under the logs no further than 50mm back from the front edge of the burner and also on the floor of the firebox at each side of the burner. **Do NOT block the ventilation slots in the burner.**

LOG POSITIONS

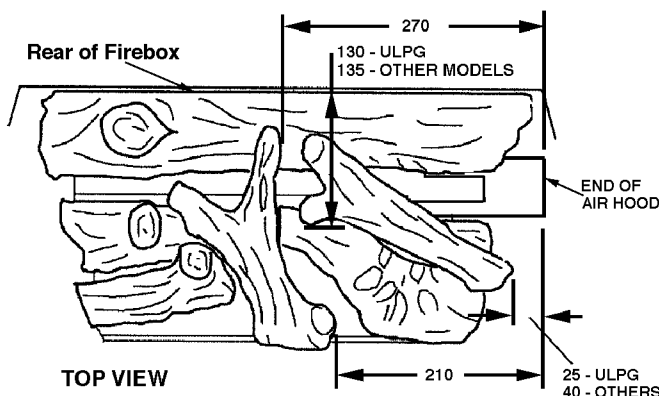

EMBER PLACEMENT

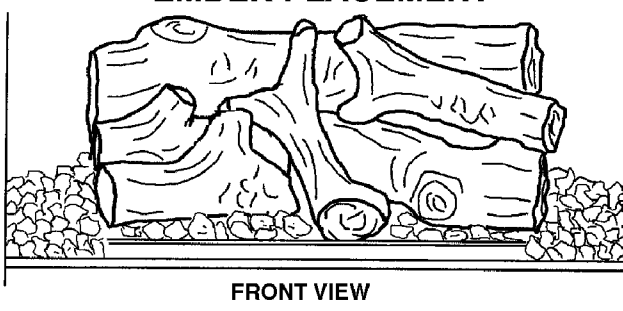

LOG IDENTIFICATION

Rear Log: Mounting centres 340mm
Left Centre Log: Mtg. crs. 115mm
Left Front Log: Mtg. crs 93mm
Right Lower Log: Mtg.crs 122mm
Right Upper Log length: 245mm
Centre Log length: 255mm

FITTING THE LOGS

Fit the first four logs on their mounting posts in the following order:-

1. The Rear Log
2. The Left Centre Log
3. The Left Front Log.
4. The Right Lower Log

Then place the Right Upper Log on top of the hollow in the right lower log maintaining the dimensions as shown.

Place the Top Log with its butt end sitting against the raised front lip of the burner. Verify the correct distances to the end of the air hood. Spread the embers as detailed above.

Re-fit the glass as described in the MAINTENANCE instructions.

SEISMIC RESTRAINT

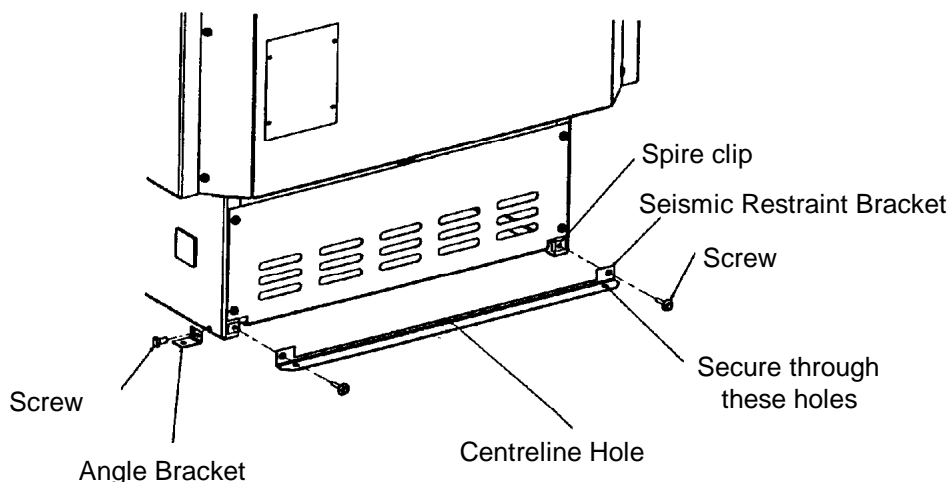

New Zealand regulations require that flued gas heaters be secured to prevent shifting in the event of an earthquake. This is best done by fastening the heater to the floor right through the floor protector if one is fitted. Fasten with two screws not less than 12 gauge or the equivalent in coach screws or toggle fasteners. Anchor the appliance through the holes in the seismic restraint bracket or in the two angle brackets supplied. (The angle brackets attach at each side of the pedestal.)

TEST FIRING

It is absolutely essential that the installer test fires the heater before leaving the site.

If fitted, open the gas supply valve at the rear of the heater and check all gas joints for leakage using a leak check solution or an electronic 'sniffer', NOT a naked flame.

Test fire the heater, following the lighting instructions on pages 2, 3 and 4 of this manual.

First check that the pilot light ignites satisfactorily. Initially it may take several attempts until the air is purged from the pipeline. Once it has lit, extinguish it again and verify instant re-ignition.

Using the appropriate procedure as detailed for the heater model, light the main burner to verify satisfactory ignition and cross-lighting. Repeat this procedure several times. Always wait two or three minutes after turning off the main burner before lighting it again. The main burner should be test run for at least ten minutes.

After the fire has been alight for five minutes on 'HIGH', hold a smoking taper or match at the exit of the draught hood (behind the heater) to verify that the flue is drawing correctly and that flue gases are not spilling into the room.

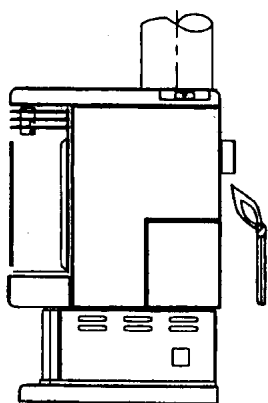

Drawn in: No spillage

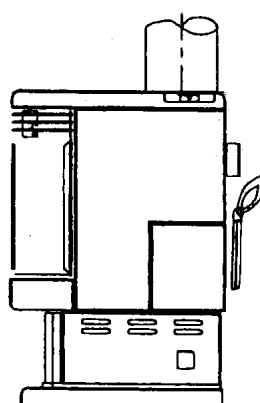

Blown out: Spillage/Backdrafting

If a wall mounted or remote thermostat is fitted, verify the thermostat action by turning the set temperature above and below the room ambient temperature to check that the burner turns on and off automatically. Hand held remote thermostats must point toward the receiver for effective operation.

If a fan is fitted, check its operation at all speeds.

If satisfactory operation cannot be achieved, contact the Retailer for further advice.

IMPORTANT. It is the responsibility of the installer to instruct the customer on the safe and correct operation of the appliance, and to ensure that this instruction booklet remains with the customer.

MAINTENANCE INSTRUCTIONS

Maintenance must be carried out only by authorised personnel.

Minor adjustments can be made with the heater in its normal operating position, but it will be found more convenient to move the heater away from the wall for major work.

If it is necessary to move the heater:-

- Shut off the gas supply at the valve behind the heater.
- Remove the access plate on the rear of the cabinet.
- Disconnect the gas line at the heater.
- Lift the flue trim about 75mm and support it with a wooden block.
- Slacken any flue clamp, and lift the flue while moving the heater from beneath it.
- Slide the heater away from the wall, supporting the flue and trim on a suitable spacer.
- Keep the heater upright at all times to avoid displacing the logs. The correct log positions are shown on page 9.

ACCESS POINTS

1. **THE CABINET REAR COVER PLATE.** This gives access to the fan and the rear of the gas control valve.
2. **THE CABINET RIGHT HAND SIDE PANEL.** The entire panel (or part of the panel in the case of Cardrona models) can be removed to give easy access to the control valve. To remove it, first withdraw two screws under the bottom flange. Pull the lower end of the side panel away from the heater until it is clear, and then lower the panel until the two locating pegs on its upper flange disengage from the cabinet. Lift it clear.
3. **THE GLASS.** See below for removal instructions. Access is then available for the log assembly, the ignition system and the main burner.
4. **THE ENTIRE CABINET** may be removed if access to the heat exchanger is necessary. First remove the glass and the cabinet right hand side panel, the rear cover plate, the fan and the draught diverter hood support plate. On Cardrona models, remove the apron below the glass. The cabinet is retained by four screws from underneath, and two screws on each front vertical edge of the firebox (three in Cardrona models).

FAN REMOVAL - All models.

Having removed the cabinet rear cover plate and the shipping nut on one of the fan locating studs, the fan assembly can be lifted vertically from the locating studs. Tip the top of the fan toward the firebox about 90 degrees and withdraw the assembly from the cabinet. If the fan needs to be separated completely from the heater, disconnect the loom at the connector plug and at the earth terminal as necessary.

GLASS REMOVAL AND ASSEMBLY – MONACO Models

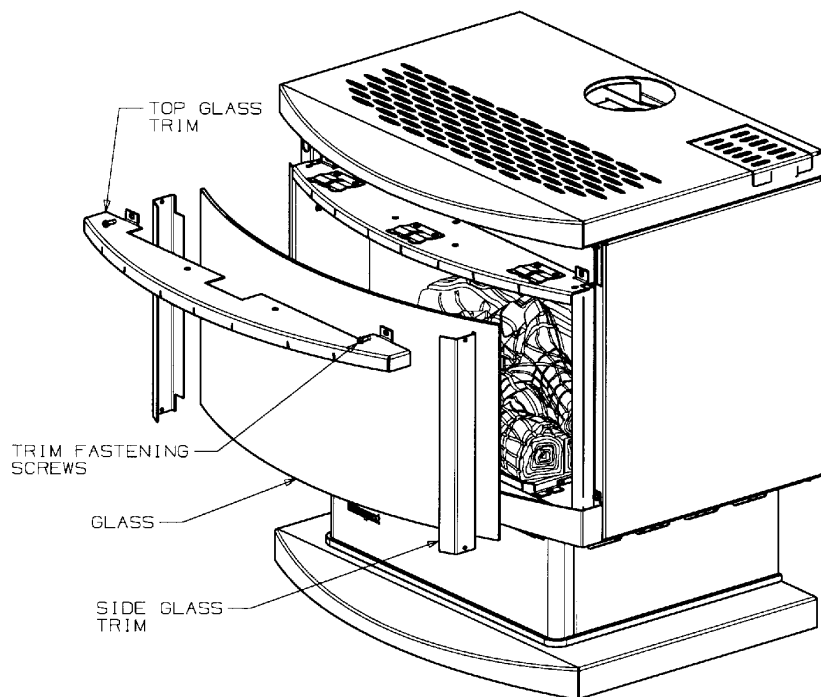

Carry out these procedures only while the heater is standing upright.

1. Remove the louvre by lifting it upwards and outwards.
2. Remove the dress guard, if fitted.
3. Remove two fastening screws securing the top glass trim.
4. Prise forward the top glass trim and lift it clear. Note. This will release the top edges of the left and right glass retainers.
5. Lift the glass retainers to remove them, keeping a hand on the glass to ensure that it does not fall.
6. Lift the glass clear.
7. Assembly is the reverse of the above. Clean the inside surface of the glass and keep fingerprints off it as it is re-assembled.
8. Place the glass in position, noting that the bottom edge of the glass has no gasket.
9. Replace the left and right glass retainers, fitting their lower ends behind the bottom glass trim.
10. Slide the top glass trim into place, making sure the top ends of the side glass retainers are captured. Fit its two fastening screws and refit the louvre.

GLASS REMOVAL AND ASSEMBLY – CARDRONA Models

Carry out these procedures only while the heater is standing upright.

1. Remove the louvre by lifting it upwards and outwards.
2. Remove the dress guard, if fitted, by first removing the bottom panel of the cabinet.
3. Remove two fastening screws securing the top glass trim.
4. Slide forward the top glass trim and lift it clear. Note. This will release the top edges of the three glass pieces. **Ensure that they do not drop out.** A masking tape strap around the glass at each front corner is useful for this.
5. Lift the front glass clear.
6. Lift each side glass clear. They will reveal at their rear edges a glass sealing rope, a backing strip and a spring.

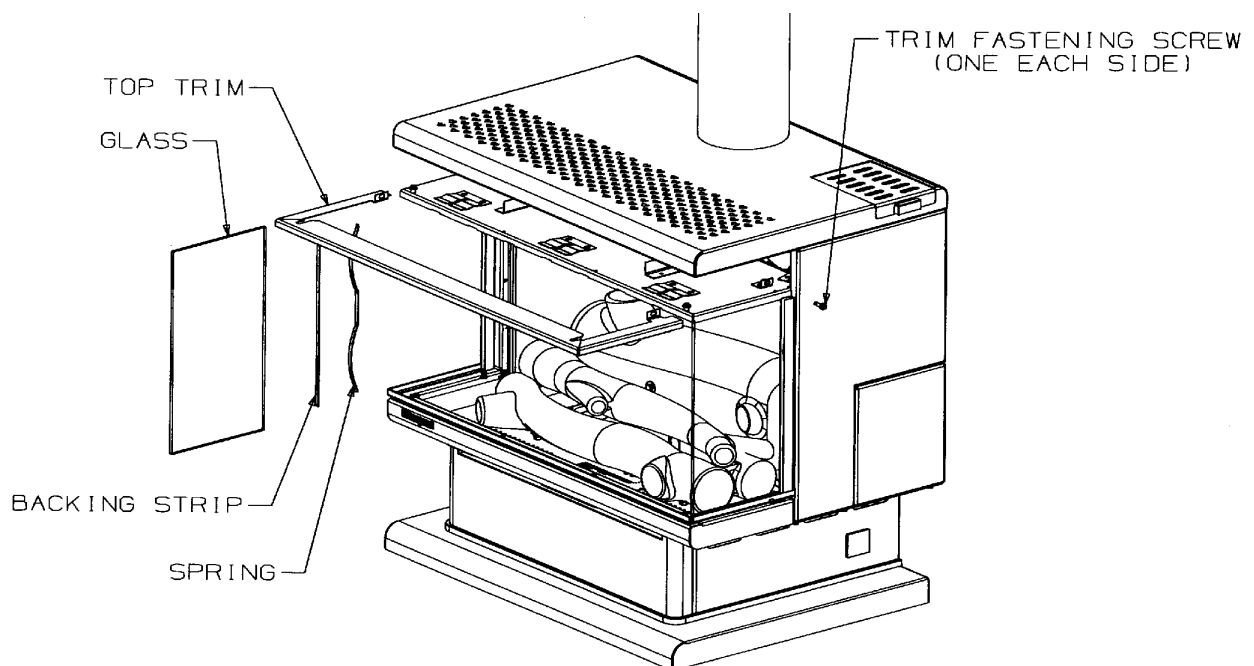

7. Assembly is the reverse of the above. Clean the inside surfaces of the glass and keep fingerprints off them as they are assembled. First assemble the side glasses to the heater. Fit the spring first, then the backing strip, then the rope and finally the glass.
8. Fit both side glasses in place so that their **SMOOTH EDGES WILL BE AGAINST THE FRONT GLASS**. The front glass can then be fitted, **TAKING CARE THAT THE BEVELLED EDGES FACE THE FRONT** (i.e. away from the side glasses). Offer the front glass into position with its lower edge just above the top of the bottom retaining channel. Press the front glass back against the side glasses, compressing the springs until it the glass is directly above the channel. Maintaining the backward pressure, slide the front glass down into the channel.
9. For safety, fix the two top front corners of the glasses together with sticky tape to prevent them from falling outwards.
10. Replace the top glass trim, fit its fastening screws, remove the sticky tape and refit the louvre.

REMOVING THE BURNER

1. Remove the glass (see above).
2. Lift all the logs out carefully, remembering they are easily damaged.
3. Remove the embers from the top of the burner.
4. Inside the firebox, remove the air hood above the right rear of the burner. (2 screws)
5. Remove the two front burner retaining screws and lift out the burner by raising the end opposite the injector (the left hand end) first, and moving the burner about 10mm to the left to disengage it from the injector. Take care to not damage the igniter assembly.
6. Lift the burner clear.

ROUTINE MAINTENANCE SCHEDULE

Your Masport heater must be serviced yearly by an Authorised Technician.

This periodic maintenance should cover the following points:-

1. Replace the battery in the igniter module (STD and ACC models only). Access the battery by pulling open the battery cover of the black plastic module mounted on the rear of the heater. One AA alkaline cell required.
2. Clean all air entry points such as primary and secondary air inlet passages.
3. Clean the main injector jet holes.
4. Clean away any carbon build-up from the pilot and igniter electrodes.
5. Clean the fan (if fitted) of any lint or foreign matter.
6. After the above steps, check the operation of the pilot, the burners and the control valve by lighting the fire.
7. Check the operation of the thermostat (if fitted) by turning the set temperature above and below the ambient room temperature and checking the response of the fire.

Other points which can be checked after completing the above are:-

1. Thermocouple generation.
2. Thermopile generation.
3. Gas consumption rate.
4. Carbon dioxide content in the combustion products.
5. The flue operation.

Note: To ensure satisfactory performance, all components fitted should be genuine Masport spare parts.

FIREBOX PAINT FINISH

The interior of the firebox is subject to extremely high flame temperatures. Whilst the painted surface is designed for high temperature durability, the combustion conditions can cause deterioration of the paint finish. This is not unique to Masport gas fires. If the surface discolours or blisters, simply scuff any loose paint from the firebox and lightly re-spray with Masport high temperature paint.

WIRING DIAGRAMS

NOTE: If the supply cord is damaged it must be replaced by the manufacturer or its service agent or a similarly qualified person in order to avoid a hazard.

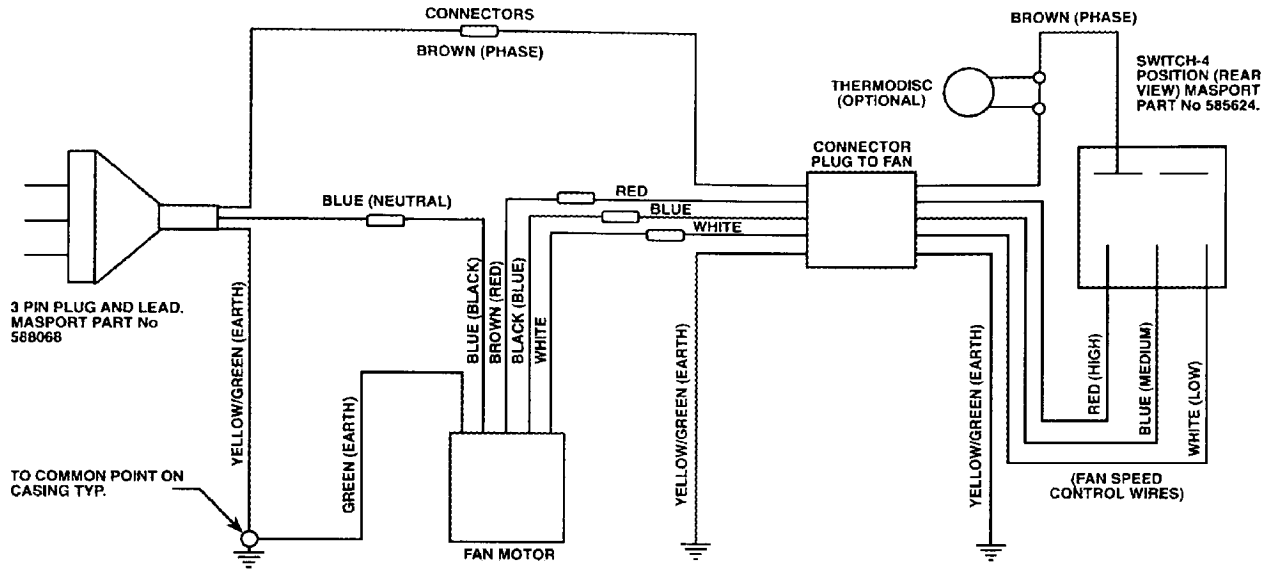

Fan Wiring Diagram - STD and ACC models.

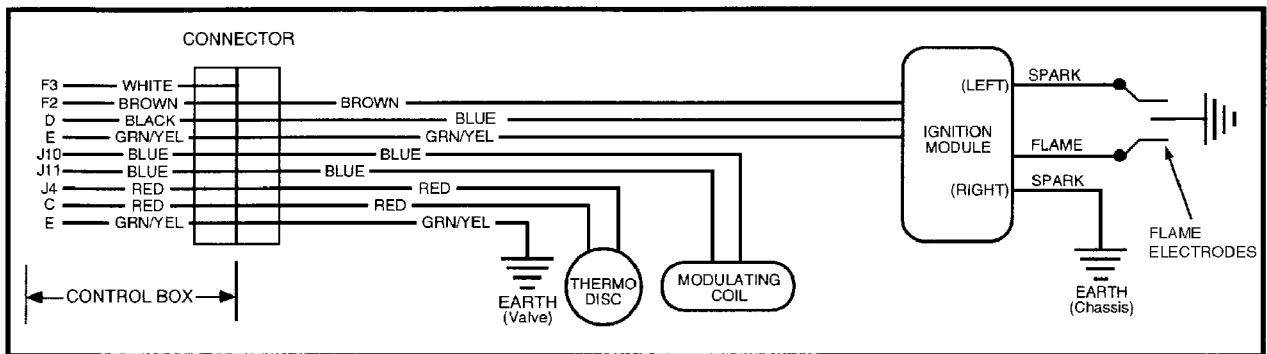

ECS IGNITION LOOM WIRING

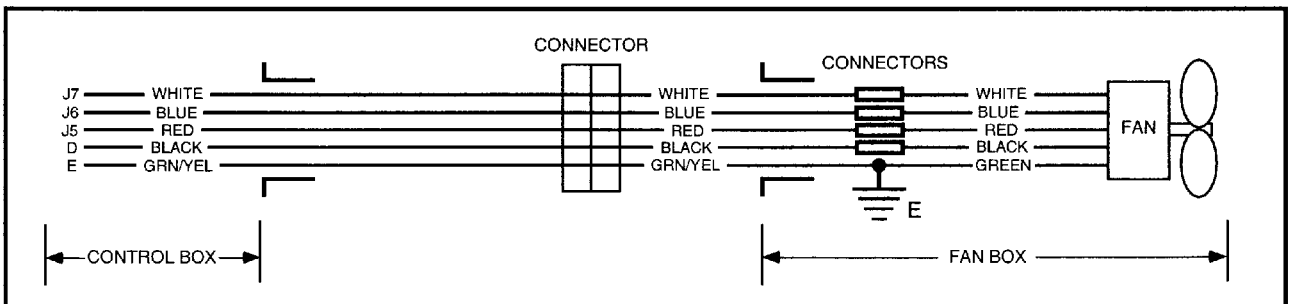

ECS FAN LOOM WIRING

TROUBLE - SHOOTING

The following table lists possible problems and their likely causes. Most of these will require a professional serviceman and we recommend that this work be performed by an Authorised Technician. If a problem cannot be solved after referring to this table, please call the Retailer from whom the appliance was purchased. Refer to your Warranty Card for details of Warranty cover.

PROBLEM	POSSIBLE CAUSE(S)	SOLUTION
There is no strong blue spark	Faulty electrode wire or wire connection(s).	Make sure wire is not shorting and connections are firm at each end.
	STD & ACC models. Faulty battery in igniter	Fit a new AA alkaline cell in igniter. (See routine Maintenance).
	ECS models. No mains supply. Room temperature is above thermostat set temperature. Handpiece faulty (no indicator light). Handpiece OK but no receiver indicator light.	Restore mains supply. Raise thermostat set temperature. Fit new batteries. Aim handpiece at receiver – move closer to receiver. Press start switch beside receiver. ECS models – turn off mains power supply for 10 seconds.
Pilot (STD & ACC models), or main burner (ECS models), will not light even though there is a strong blue spark.	Air in pipeline.	Repeat starting attempts until air is cleared.
	Stale gas in pipeline after non-use for an extended period (Propane and ULPG gases)	Bleed pipeline or persist with starting attempts.
	Incorrect lighting procedure.	Follow the instructions in this manual.
	No gas supply at heater.	Check for closed gas valve(s) or faulty gas supply lines.
	Pilot jet blocked. (ACC only)	Clean jet
	Pilot filter blocked.	Replace the filter under the large screw on top of the control valve (STD only).
	No fuel in LPG system.	Replenish LPG supply.
Pilot stays alight but main burner will not light. (ACC models)	Thermostat, (where fitted), is switched to OFF or set to a low temperature.	Check thermostat setting. Switch to ON or set to a higher temperature.
Smell of flue gas in the room.	Flue gas spilling from the draught diverter at the rear of the heater.	Check for flue blockage, negative air pressure in the room or circumstances causing down-draught.

TROUBLE - SHOOTING (Continued)

PROBLEM	POSSIBLE CAUSE(S)	SOLUTION
Ignition spark continues after the fire has lit. (ECS models only)	Phase and Neutral connections reversed in the house power supply.	Get a qualified person to correct the house wiring.
Smell of gas in the room.	Pipe fittings may be leaking.	Check all joints for leaks, including the gas supply system, the pilot light supply tube, the main burner supply tube and all connections to the control valve and the pressure reducing valve on STD models. Use ONLY a proper leak check solution. NEVER USE AN OPEN FLAME TO CHECK FOR LEAKS.
A thin coating of black soot forms inside the glass.	Combustion air supply restricted.	Clean all primary and secondary air passageways.
	Over-supply of gas.	Adjust gas delivery pressure at test point.
	Logs out of position.	Arrange logs correctly.
A white coating forms inside the glass.	Residues of new logs being burned off.	Follow glass cleaning directions under Maintenance Instructions.
Fan hums but there is poor air circulation.	Dirty fan impeller.	Disconnect electrical power. Withdraw fan and clean impeller.
Fan will not run.	No power to fan. Faulty Thermodisc (Monaco models only) or wiring. Loose fan loom plug. Handpiece for ECS model ineffective	Fan should not run until firebox is hot (Monaco models only). Call serviceman. Check after removing fan. Aim at receiver.– fit new batteries.
Fire cycling on and off too rapidly.	Thermostat models only. A large fire in a small room. Incorrect positioning of thermostat.	Turn flame down to a lower setting. Move hand thermostat or wall thermostat further away from heater hot air stream.

