





Masport

Grande Provincial Built-in (Zero Clearance) Kit Instructions.

Grande Provincial ZC Kit contains:

Part No.	Quantity	Description	Picture
503259	4	Self Threading Screw 13mm	
503459	6	Self Threading Screw Timbertites	
503388	2	Spire Nut	
503704	34	Self Threading Screw 16mm	
595688	1	Adapter Ring	
995154/ 995155	1	LH Side Assy	
995154/ 995692	1	RH Side Assy	
995157/ 995158	1	Rear Assy	
995160/ 995161	1	Bottom Assy	
995164	1	Top Panel	
995163 / 995166	1	Top Shield Assy	
995196	2	Seism. Restraint Bracket	

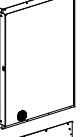
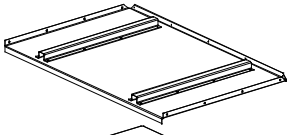
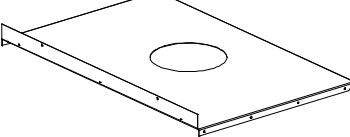
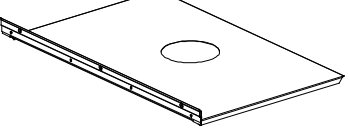
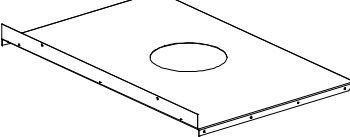
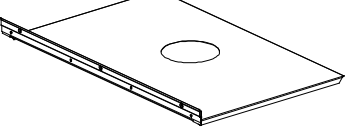
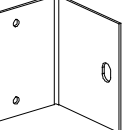
Part No 595165.i.0

04/05/05

The kit enables the Masport Grande Provincial Woodfire to be installed when no conventional masonry chimney is available. The woodfire will need a shielding box, a special flue kit, a ventilated top fascia rail, and a bottom fascia rail. The installation may be made onto a timber or particle board floor or a concrete floor. (See Special Constructions below for concrete floors). We recommend following the sequence below.

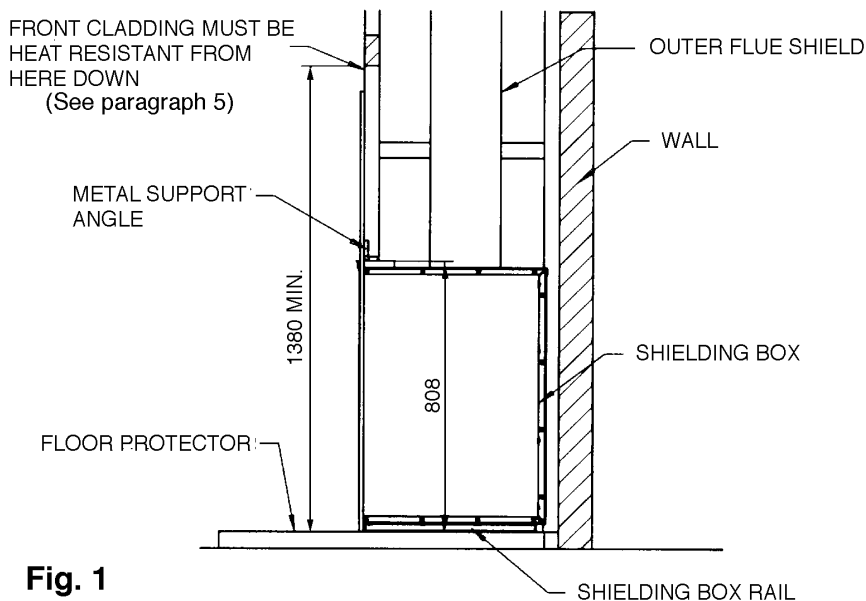

Fig. 1

STANDARD INSTALLATIONS:

1. Inspect the house construction at the proposed installation position to verify that the flue shield (250mm diameter, plus 25mm clearance all around) can pass right up through the ceiling space without requiring the removal of essential roof or ceiling support beams. The flue centreline will be 277 mm out from the rear wall and it must be at least 730mm distant from any side wall. (See Fig. 2).

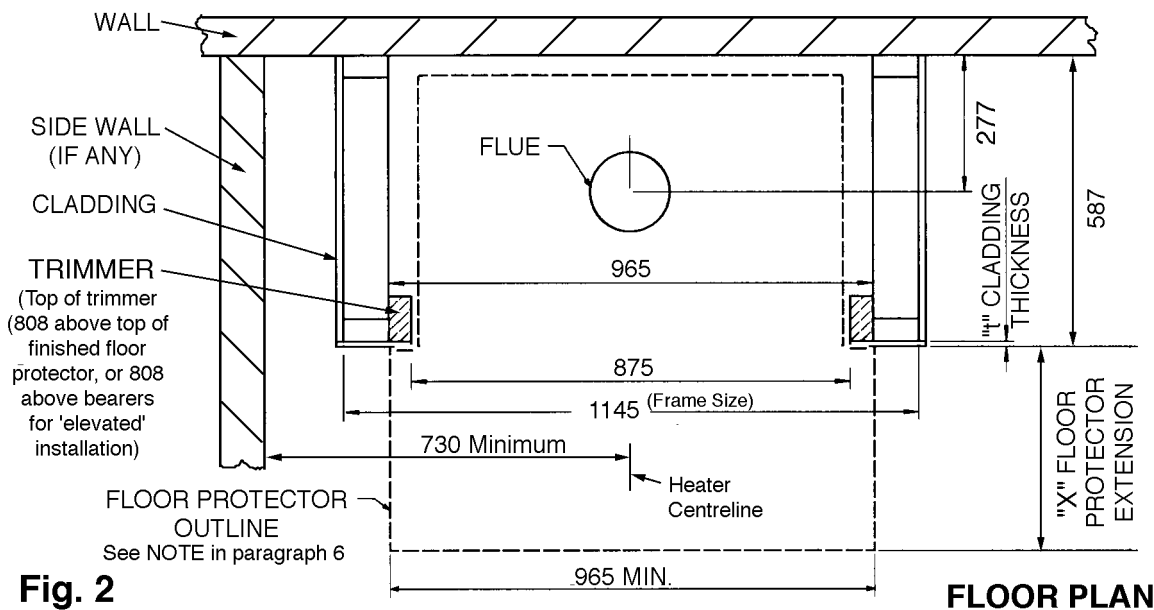

Fig. 2

2. Drop a plumb line from the ceiling to the floor to verify the centreline and cut a hole at least 300mm square through the ceiling on this centreline. If preferred, there may be no ceiling inside the fireplace enclosure. (See step 12)
3. Ensure that there are suitable nogs at either the ceiling or roof level (or both) to provide anchorage for the outer flue heat shield bracing angles.
4. Frame up the **enclosure** using nominal 90 by 45 dressed timber, verifying that it will be on the flue centreline. (See Fig. 3). The overall depth of the frame should be $(587 - t)$ mm, where 't' is the cladding thickness. The distance between the trimmers (where the assembled shielding box will fit), should be 875mm. The overall width of the enclosure frame shown is the minimum required, but if desired it may be larger. The trimmers do not run the full height, but end 808 mm above the finished top face of the floor protector (or 808 mm above the top of the bearers if the heater is 'elevated'). Refer to paragraph 6 for floor protector thickness options and the advantage of 'elevated' installations. Fix the metal support angle across the tops of the trimmers to provide support and fixing for the front heat resistant cladding.

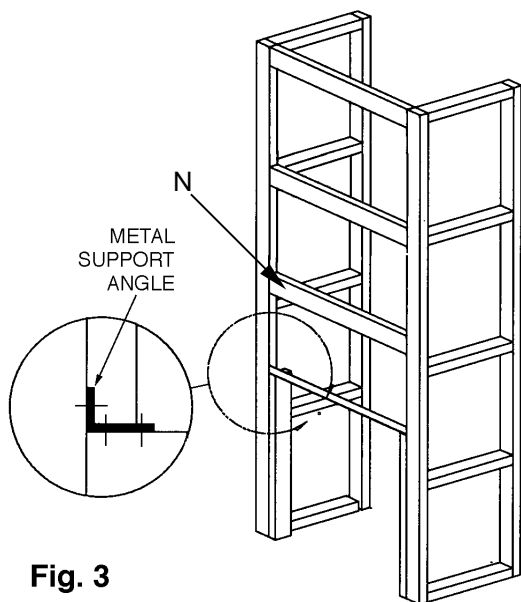

Fig. 3

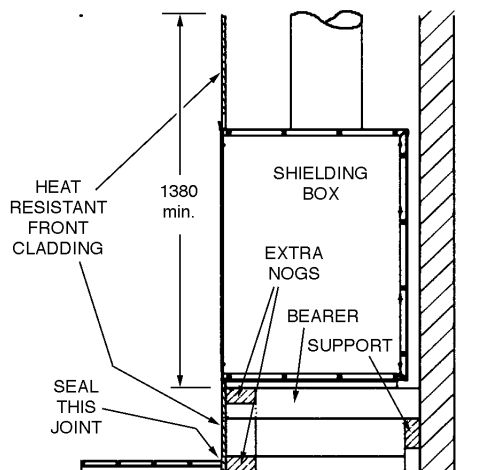

Fig. 4 ELEVATED INSTALLATION

For an 'elevated' installation, fix two **extra nogs** (90x45x875 mm) across the front opening of the enclosure, one at the bottom and the other at the desired 'elevation' height. (See Fig. 4). These **extra nogs** will carry the front cladding below the heater. Fix two 90 x 45 **bearers** running from front to back behind the top extra nog., positioned 250 mm each side of the enclosure centreline to provide support for the shielding box rails. The **bearer** tops must be flush with the top of the **top extra nog**. Provide a suitable **support** at the rear ends of the bearers to carry the weight of the appliance. (See Fig. 4). The shielding box rails can sit directly on the bearers. No insulation is necessary. The usual three nogs may be fixed at each side of the enclosure. At the front, the lowest wooden nog **N** must have its lower face at least 1380 mm above the top of the floor protector (or 1380 mm above the bearers for an elevated installation). Further wooden nogs can be fitted at the front above this one.

5. Fix the cladding to the **front** of the enclosure, including down each side of the 808 x 875 opening. All **front cladding** (including cladding below the heater in elevated installations) which is less than 1380 mm above the floor protector (or the bearers in elevated installations), must be of heat-proof material such as Hardies Tile and Slate Underlay, Hardiflex or Supalux. **Wall surfaces directly above the heater may reach 85 degrees C, so materials such as wallpaper and water based paint may be adversely affected. For durability of finishes and surfaces you should contact the relevant manufacturer for their specifications. Masport accepts no responsibility for the deterioration of surfaces of finishes.** It is usually convenient to carry the same material right up to ceiling level. At the lower edge, drill (4.5 mm diameter) into the metal support angle through the holes in the top flange of the shielding box and fasten with the self threading screws provided. The **side cladding** for the enclosure may be Gib board or any other wall cladding material. For ease of flue installation, leave the cladding off at least one side until the flue system has been installed.
6. For heat sensitive floors, construct a floor protector of the shape shown in the Floor Plan above (Fig. 2). (See page 4 for concrete floors). The standard floor protector is constructed of two layers of 6mm fibre cement board (such as Hardies Tile and Slate Underlay), topped with a layer of tiles or slate. This will give a thickness of approximately 20mm, and the extension from the face of the front cladding must be at least 440 mm. The floor protector must be at least 965 mm wide.

If it is desired to reduce the extension of the floor protector to its minimum allowable size (335 measured from the front cladding or 300 from the door opening), this can be done in two ways:-

- By increasing the thickness of the floor protector to at least 95 mm. (The shielding box must be raised to the new height also.)
- By keeping the 20 mm floor protector thickness and raising the shielding box 90 mm above the top of the floor protector on bearers as described in paragraph 4. (An 'elevated' installation).

In all cases, the width of the required floor protector must be at least 965 mm, but the appearance will be enhanced if it is at least as wide as the fascia (1095 mm).

NOTE: For elevated installations, the floor protector may be installed after the heater is in position as it does not extend into the enclosure. However, its rear edge must butt up against the face of the heat-proof cladding below the heater, and the joint at that point must be sealed to prevent the possibility of ember penetration.

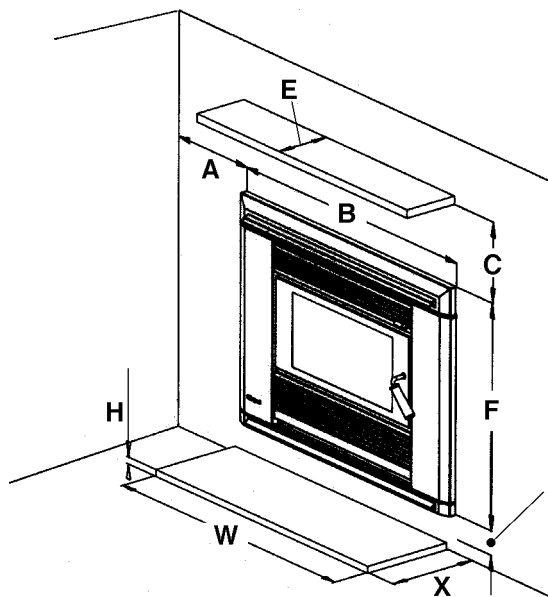

A Min.	B	F	W Min.	C Min.	E Max.	H	X Min.
185	1095	830	§ 965	300	150	20	Δ 440
				515	250		95

Δ 335mm with 90 or more elevation

§ Increase to match or exceed fascia width B for an enhanced appearance

All floor protectors must have at least 335mm extension from the surround (300mm extension from the door opening)

Fig 5.

7. Cement tiles or slate to the top of the floor protector. The part inside the enclosure will not be visible and therefore does not need complete coverage. It is necessary to fix the finishing layer only under the support rails in this area. The visible edges of the floor protector are best finished with wooden trim or tiles after the stove has been installed.
8. Penetrate the roofing material on the flue centreline. Working from the bottom, assemble sections of the flue and the inner and outer flue heat shields (casings) and pass them up through the hole in the roof. Remember the flue sections must be fixed together at each joint with at least two rust-proof fasteners, and the crimped ends of the flue heat shields go to the top. When the flue system is finally in position, the inner shield must extend up past the roof penetration point and the outer shield must be sufficiently high to avoid down-draughts in the finished flue. If the flue centreline is within 3m of the ridge, the outer shield must end at least 600mm above the roof ridge. If it is further than 3m from the ridge, the shield must extend at least 900mm above the point of roof penetration. In some cases where there are trees or high buildings in the vicinity, it may be necessary to increase this height to avoid down-draughts. Note that the 200mm adapter ring (with holes which ventilate the space between the flue and the inner shield) will be fitted into the shielding box assembly and will engage in the bottom of the inner heat shield (see Fig. 7). Fit a temporary support to hold the flue system high enough to permit sliding in the shielding box.
9. Assemble the base, sides, back and top panel of the shielding box (see Fig. 6). Slide the assembly into place in the enclosure. After centralising, fix the flange of the top panel of the shielding box through the cladding into the metal angle support, and fix the side flanges (through the cladding) into the wooden trimmers. Pass the 200mm adapter ring (crimped end up) upwards into the hole in the top panel of the shielding box, and slide the top shield in under it so that the ring sits on top of the top shield and the top shield rests on the top edges of the inner heat shields of the cabinet. Make sure the back flange of the top shield hooks over the shield on the rear panel. Fix the top shield to the front flange of the top panel with 3 screws.

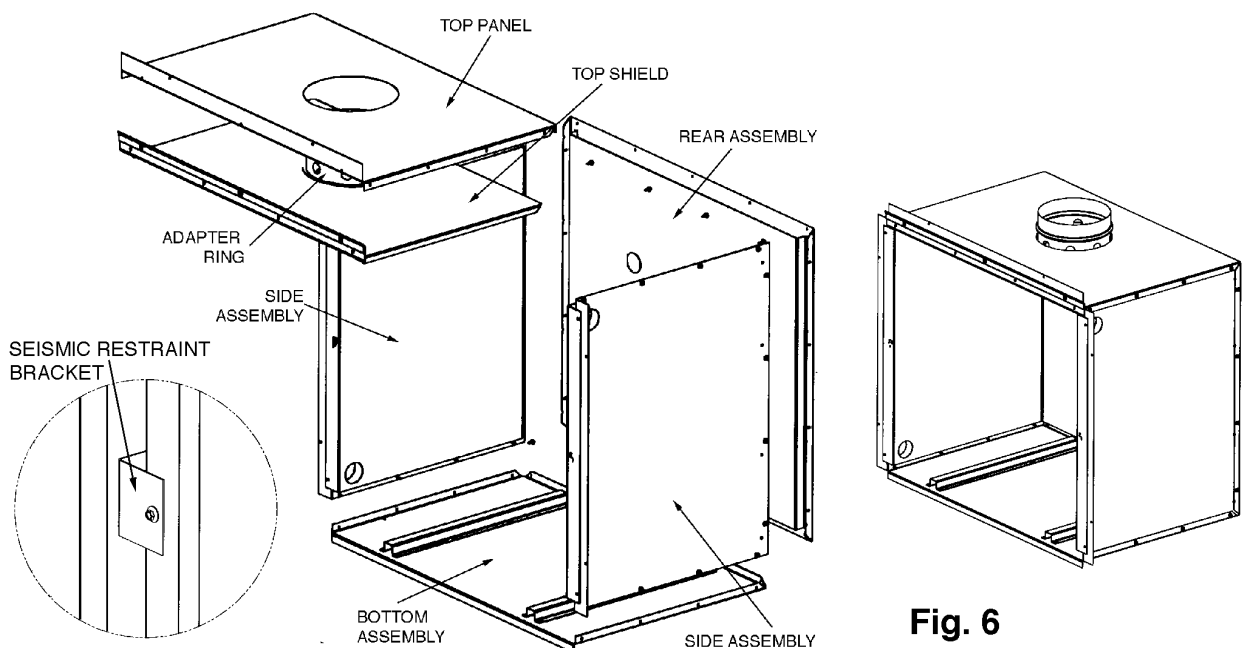

Fig. 6

10. Remove the two retaining screws and slide out the removable top section of the **firebox** cabinet. Fix the seismic restraint brackets at each side of the firebox cabinet (flanges facing outwards), and slide the firebox cabinet into the shielding box. Centralise it and secure the restraint brackets to the shielding box flanges.
11. Lower the assembled flue and **seal and fix it to the flue socket** of the heater. Lower the inner flue heat shield and engage its bottom end with the adapter ring. Lower the outer flue heat shield to sit on top of the shielding box.
12. Fit the two shield bracing angles at either ceiling or roof level as appropriate. Fix a suitable flashing where the outer shield penetrates the roof.
13. **IMPORTANT. TO AVOID THE RISK OF A FIRE, COVER THE ENTIRE OPEN SPACE SURROUNDING THE HEAT SHIELD AT CEILING LEVEL WITH WIRE NETTING WHICH HAS A MESH SMALL ENOUGH TO PREVENT THE ENTRY OF BIRDS OR VERMIN INTO THE ENCLOSURE.**
14. At the top of the flue, fix the flashing cone and fit the flue cowl in the usual way.
15. Re-fit the removable top section of the firebox cabinet and secure it with two screws.
16. Fix the cladding to the enclosure side(s).
17. An un-shielded mantel-shelf may be fitted according to the height and width restrictions shown in Fig. 5. Shelves lower or wider than shown require a metal under-shield (see the installation manual).
18. Remove the standard top rail of the fascia and replace it by the vented one. Remove the bottom bar of the fascia and replace it by the vented bottom rail, taking care to trap the mains lead and grommet between the left end of the bottom rail and the left fascia upright. If necessary, replace the electrical connections at the rear of the fan switch (see installation manual) and ensure that the earth wire is connected to the post behind the Masport badge on the left fascia upright.
19. Fit the fascia by offering it up to the heater about 15 mm above its final position and lowering it, making sure the lip behind the top fascia rail engages in the slot at the top of the shielding box. Fit the six retaining screws.
20. Fit the upper and lower fascia grilles and the firebox door as described in the installation manual.
21. Finish the floor protector by installing an edge trim if desired.

SPECIAL CONSTRUCTIONS:

CONCRETE FLOORS: The above instructions assume that the heater is being assembled on a heat sensitive floor such as timber or particle board. Where the floor is not heat sensitive (e.g. concrete), the insulating floor protector may be omitted. However, if heat sensitive floor coverings are fitted it will be necessary to keep them at a safe distance. The most practical way to do this is to fix tiles to the floor where the floor protector would normally be. This will make the top of the protector approximately flush with the floor covering, so a larger floor protector will be needed. It must extend out to 500 mm from the face of the fireplace surround, but the 965 mm width will be sufficient.

EXTERNAL INSTALLATIONS: In the case where the enclosure is to be erected outside the house, the shielding and flue installation details above will still apply. It is important to remember that the aperture in the wall of the house will need to be sufficiently high to permit the installation of heat resistant panelling in front of the heater to at least 1380 mm above the bottom of the shielding box rails. Suitable foundations will be required to support the weight of the enclosure and the heater and weatherproofing of the entire assembly will be necessary.

BRICK FACED INTERNAL ENCLOSURES:

Flue installation and clearance requirements are as detailed above. Brick wall construction will normally require a cast concrete base slab, so this slab could be extended to provide the necessary floor protection.

CAUTION. If local Building Requirements permit laying the concrete slab on top of a wooden floor, it should be made of lightweight concrete and even then foundation support may be required. In any case, the slab should be poured on top of one layer of Micore 160 board (covered with sheet plastic to keep it dry) to prevent heat damage to the wooden floor. The top surface can be finished with bricks or tiles etc. In all cases the floor protector dimensions must be as previously shown.

As before, the opening for the appliance in the front wall must be 875mm wide and 808 mm high. Note that the bricks above the opening must extend to at least 1380 mm above the bottom of the shielding box rails.

Fit the shielding box and complete the installation as previously detailed for standard installations.

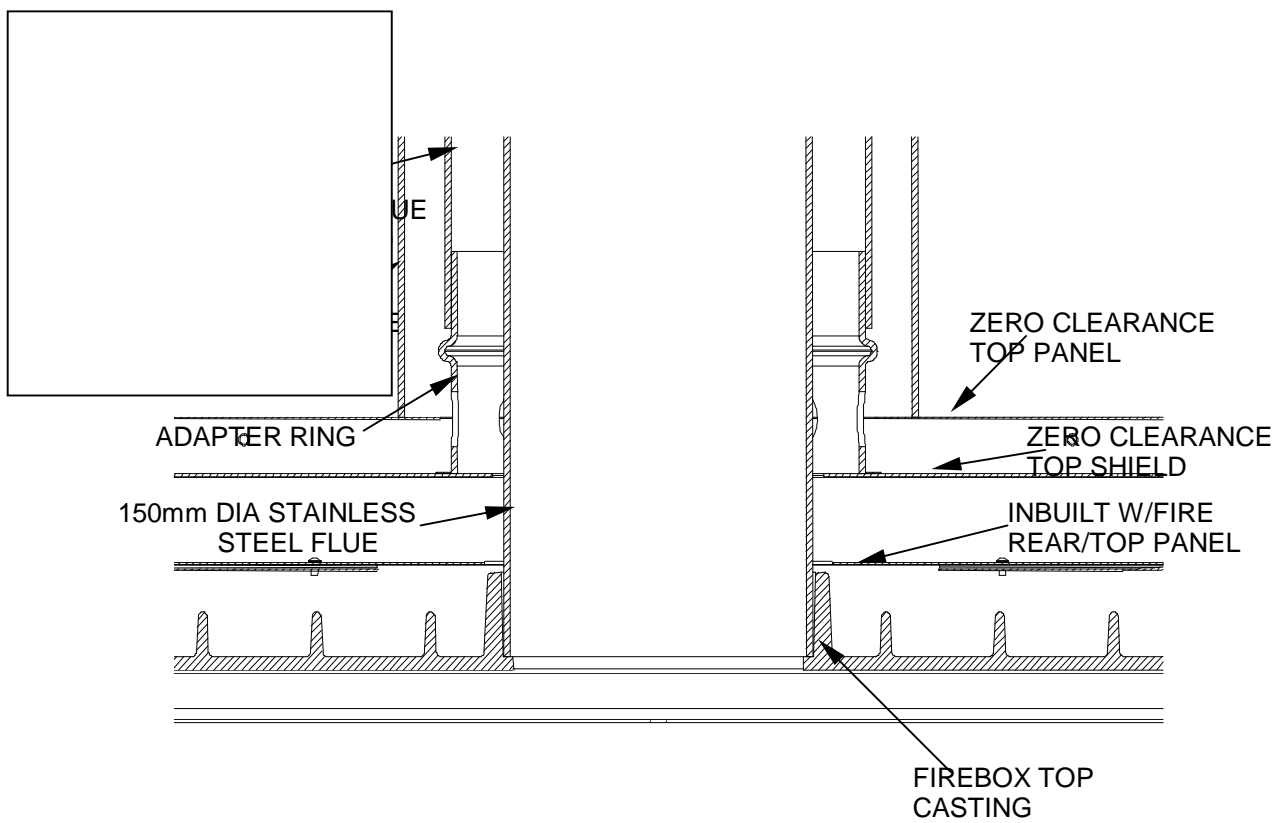

Fig. 7

